

C-LOK

C-LOK Instrument Valve Co.,Ltd.

Weld Fittings

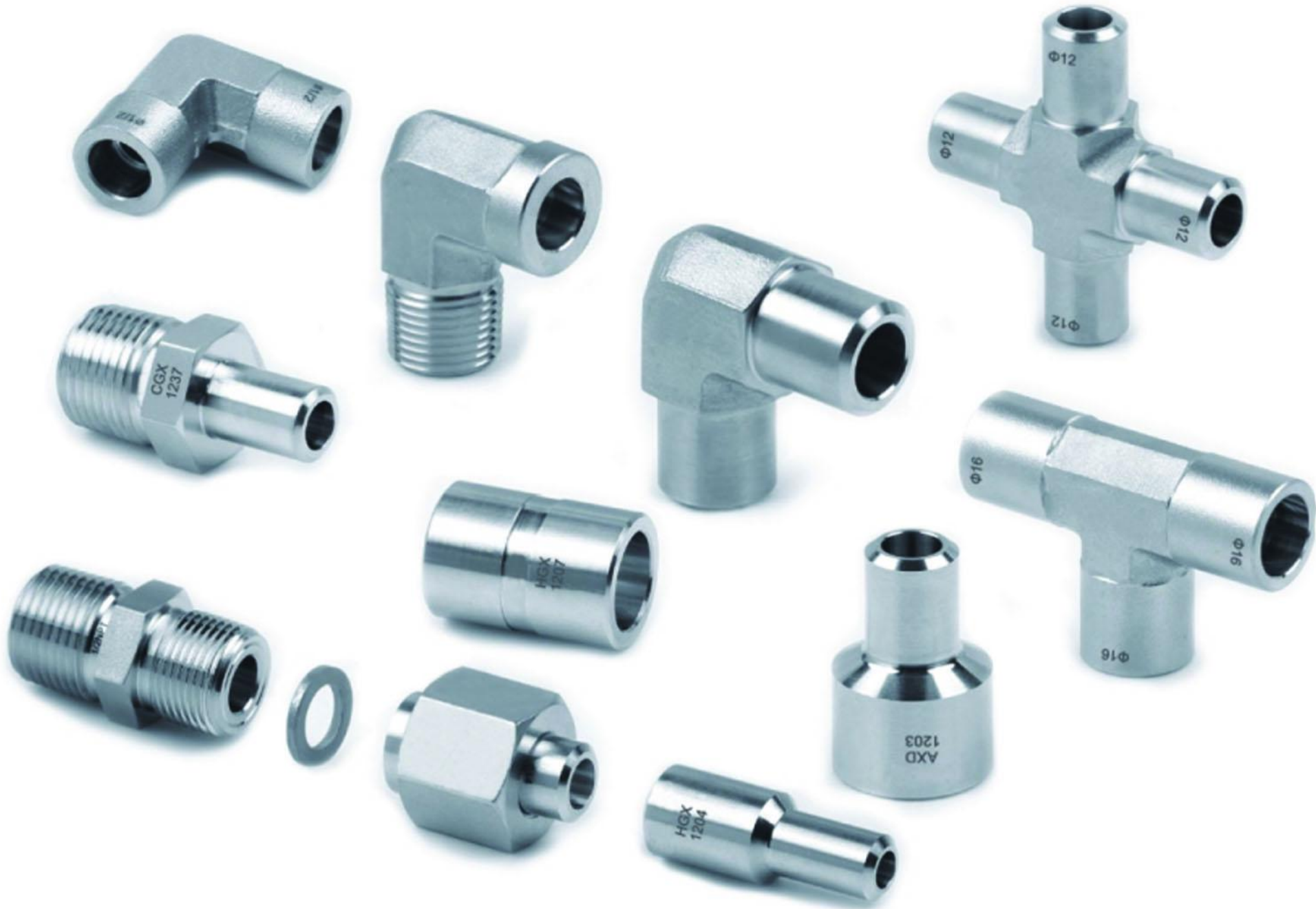

Contents

Tube Butt Weld Fittings

03 Male Connectors

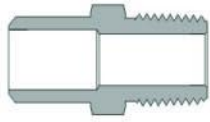

03 Female Connectors

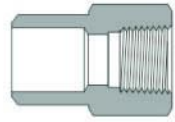

04 Reducing Unions

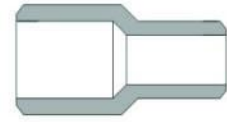

05 Union Elbows



05 Union Tees

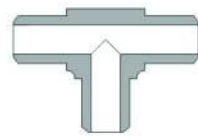

06 Union Crosses

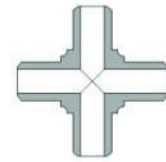

Tube Socket Weld Fittings

07 Male Connectors

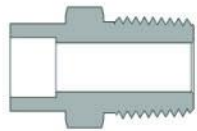

07 Female Connectors

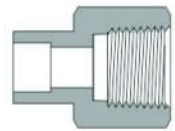

08 Male Elbows



08 Female Elbows



09 Unions

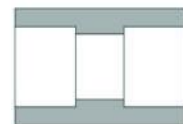

09 Reducing Unions

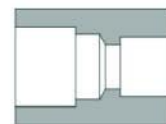

Contents

10 Union Elbows



10 Union 45° Elbows



10 Union Tees

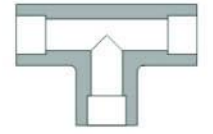

11 Union Crosses

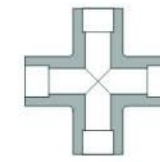

Pipe Butt Weld Fittings

12 Male Connectors

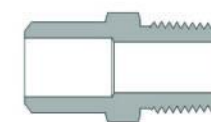

12 Female Connectors

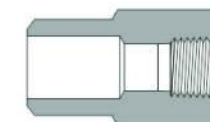

Pipe Socket Weld Fittings

13 Male Connectors

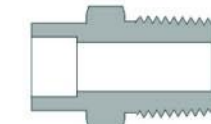

13 Female Connectors

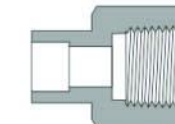

13 Unions

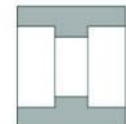

Weld Apapters

14 Tube-Butt-Weld to Tube Socket Weld

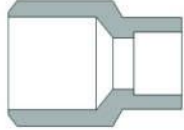

14 Pipe-Butt-Weld to Tube Socket Weld

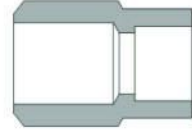

Features

- 316 stainless steel material is standard, Other materials are available upon request.
- Straight fittings are manufactured from quality bar stock. Shaped fittings are manufactured from forgings.
- Quality machining of all ports ensures proper connection.
- Radius junction design with elbows provides smooth flow path.
- All fittings are cleaned to remove oil, grease, and loose particles.
- Every fitting is stamped with size, material, and heat code.

Technical Data

- Sizes range from 1/8" to 1" and 6 mm to 38mm.
- Working Pressure
Catalog working pressures shown are based on ANSI/ASME B31.3, to determine working pressures in accordance with ANSI/ASME B31.1 multiply catalog working pressures shown by 0.94.
- Working Temperature

| Material | Minimum Temperature | Maximum Temperature |
|----------|---------------------|---------------------|
| 316 SS | -325°F (-198°C) | 1000°F (538°C) |
| 316L SS | -325°F (-198°C) | 850°F (454°C) |
| 316H SS | -325°F (-198°C) | 1200°F (649°C) |
| 321 SS | -325°F (-198°C) | 1000°F (538°C) |
| 304 SS | | |

Materials

| Material | Designator | Bar Stock | Forgings |
|----------|------------|-----------------------|-----------------------|
| 316 SS | SS | ASTM A276, ASME SA479 | ASTM A182, ASME SA182 |
| 316L SS | 6L | | |
| 316H SS | 6H | | |
| 321 SS | S1 | | |
| 304 SS | S4 | | |

Ordering Information

- Add the material designator as a prefix to the basic ordering number to get the complete ordering number. Example: 6L-WM-BW4-NT4
- To order fittings with special cleaning and packaging to ensure compliance with cleanliness requirements as stated in ASTM G93 Level C, add-G93C as a suffix to the ordering number. Example: SS-WM-BW4-NT4-G93C.

Cautions

- Using the same materials to weld will ensure the same coefficients of expansion and good weld
- Tungsten Inert Gas Welding (TIG) will be a good welding methods.
- Dimensions in mm unless otherwise specified, are for reference only and are subject to change.

Male Connectors

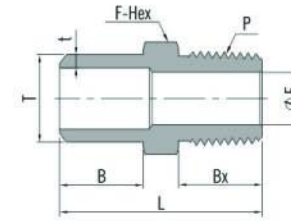

| Fractional Tube | | | | NPT Thread | | | | | Working Pressure psig(bar) |
|-------------------|------------------------|------------|-----------------------|---------------|------|------|------|------|----------------------------|
| T-Tube Size (in.) | t-Wall Thickness (in.) | P-NPT Size | Basic Ordering Number | Dimension, mm | | | | | |
| | | | | L | B | Bx | F | E | |
| 1/4 | 0.065 | 1/4 | -WM-BW4-NT4 | 29.7 | 9.7 | 14.2 | 14.3 | 7.1 | 8000(551) |
| 1/4 | 0.065 | 1/2 | -WM-BW4-NT8 | 36.8 | 9.7 | 19.1 | 22.2 | 11.9 | 7700(530) |
| 3/8 | 0.095 | 1/4 | -WM-BW6-NT4 | 29.7 | 9.7 | 14.2 | 14.3 | 7.1 | 8000(551) |
| 3/8 | 0.095 | 1/2 | -WM-BW6-NT8 | 36.8 | 9.7 | 19.1 | 22.2 | 11.9 | 7700(530) |
| 1/2 | 0.095 | 1/4 | -WM-BW8-NT4 | 34.3 | 14.2 | 14.2 | 14.3 | 7.1 | 6780(468) |
| 1/2 | 0.095 | 1/2 | -WM-BW8-NT8 | 41.1 | 14.2 | 19.1 | 22.2 | 11.9 | 6780(468) |
| 5/8 | 0.109 | 1/4 | -WM-BW10-NT4 | 34.8 | 14.2 | 14.2 | 17.5 | 7.1 | 5760(397) |
| 5/8 | 0.109 | 1/2 | -WM-BW10-NT8 | 41.4 | 14.2 | 19.1 | 22.2 | 11.9 | 5760(397) |
| 3/4 | 1.120 | 1/4 | -WM-BW12-NT4 | 40.1 | 19.1 | 14.2 | 20.6 | 7.1 | 5530(381) |
| 3/4 | 0.120 | 1/2 | -WM-BW12-NT8 | 46.2 | 19.1 | 19.1 | 22.2 | 11.9 | 5530(381) |
| 1 | 0.134 | 1/4 | -WM-BW16-NT4 | 42.9 | 19.1 | 14.2 | 27.0 | 7.1 | 4480(409) |
| 1 | 0.134 | 1/2 | -WM-BW16-NT8 | 47.8 | 19.1 | 19.1 | 27.0 | 11.9 | 4480(309) |

| Metric Tube | | | | NPT Thread | | | | | Working Pressure psig(bar) |
|------------------|-----------------------|------------|-----------------------|---------------|------|------|----|------|----------------------------|
| T-Tube Size (mm) | t-Wall Thickness (mm) | P-NPT Size | Basic Ordering Number | Dimension, mm | | | | | |
| | | | | L | B | Bx | F | E | |
| 12 | 2.2 | 1/4 | -WM-MB12-NT4 | 34.3 | 14.2 | 14.2 | 14 | 7.1 | 6470(446) |
| 12 | 2.2 | 1/2 | -WM-MB12-NT8 | 41.1 | 14.2 | 19.1 | 22 | 11.9 | 6470(446) |
| 14 | 2.5 | 1/4 | -WM-MB14-NT4 | 34.3 | 14.2 | 14.2 | 15 | 7.1 | 6280(433) |
| 14 | 2.5 | 1/2 | -WM-MB14-NT8 | 41.4 | 14.2 | 19.1 | 22 | 11.9 | 6280(433) |
| 15 | 2.5 | 1/4 | -WM-MB15-NT4 | 34.8 | 14.2 | 14.2 | 16 | 7.1 | 5770(398) |
| 16 | 2.8 | 1/4 | -WM-MB16-NT4 | 35.6 | 14.2 | 14.2 | 18 | 7.1 | 6140(423) |
| 16 | 2.8 | 1/2 | -WM-MB16-NT8 | 41.1 | 14.2 | 19.1 | 22 | 11.9 | 6140(423) |
| 20 | 3.0 | 1/2 | -WM-MB20-NT8 | 46.2 | 19.1 | 19.1 | 22 | 11.9 | 5110(352) |
| 22 | 3.0 | 1/4 | -WM-MB22-NT4 | 41.2 | 19.1 | 14.2 | 24 | 7.1 | 4620(319) |
| 22 | 3.0 | 1/2 | -WM-MB22-NT8 | 46.1 | 19.1 | 19.1 | 24 | 11.9 | 4620(319) |
| 25 | 3.5 | 3/4 | -WM-MB25-NT12 | 47.8 | 19.1 | 19.1 | 27 | 15.7 | 4730(326) |
| 25 | 3.5 | 1 | -WM-MB25-NT16 | 54.9 | 19.1 | 23.9 | 35 | 22.4 | 4730(326) |
| 28 | 4.0 | 1/2 | -WM-MB28-NT8 | 54.2 | 21.4 | 19.1 | 30 | 11.9 | 4850(335) |

Female Connectors

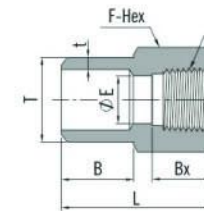

| Fractional Tube | | | | NPT Thread | | | | | Working Pressure psig(bar) |
|-------------------|------------------------|------------|-----------------------|---------------|------|------|------|-----|----------------------------|
| T-Tube Size (in.) | t-Wall Thickness (in.) | P-NPT Size | Basic Ordering Number | Dimension, mm | | | | | |
| | | | | L | B | Bx | F | E | |
| 1/4 | 0.065 | 1/4 | -WF-BW4-NT4 | 27.9 | 9.7 | 15.0 | 19.1 | 3.0 | 6600(454) |
| 1/4 | 0.065 | 3/8 | -WF-BW4-NT6 | 29.5 | 9.7 | 15.0 | 22.2 | 3.0 | 5300(365) |
| 3/8 | 0.095 | 1/4 | -WF-BW6-NT4 | 27.9 | 9.7 | 15.0 | 19.1 | 4.7 | 6600(454) |
| 3/8 | 0.095 | 3/8 | -WF-BW6-NT6 | 29.5 | 9.7 | 15.0 | 22.2 | 4.7 | 5300(365) |
| 1/2 | 0.095 | 1/4 | -WF-BW8-NT4 | 34.0 | 14.2 | 15.0 | 19.1 | 7.9 | 6300(454) |
| 1/2 | 0.095 | 3/8 | -WF-BW8-NT6 | 34.0 | 14.2 | 15.0 | 22.2 | 7.9 | 5300(365) |
| 1/2 | 0.095 | 1/2 | -WF-BW8-NT8 | 38.9 | 14.2 | 19.8 | 27.0 | 7.9 | 4900(337) |

| Metric Tube | | | | NPT Thread | | | | | Working Pressure psig(bar) |
|------------------|-----------------------|------------|-----------------------|---------------|------|------|----|------|----------------------------|
| T-Tube Size (mm) | t-Wall Thickness (mm) | P-NPT Size | Basic Ordering Number | Dimension, mm | | | | | |
| | | | | L | B | Bx | F | E | |
| 14 | 2.5 | 1/4 | -WF-MB14-NT4 | 33.0 | 14.2 | 15.0 | 19 | 9.0 | 6280(433) |
| 14 | 2.5 | 1/2 | -WF-MB14-NT8 | 38.9 | 14.2 | 19.8 | 27 | 9.0 | 4900(337) |
| 20 | 3.0 | 1/2 | -WF-MB20-NT8 | 43.7 | 19.1 | 19.8 | 27 | 14.0 | 4900(337) |
| 28 | 4.0 | 1/2 | -WF-MB28-NT8 | 49.8 | 23.9 | 19.8 | 30 | 15.7 | 4850(335) |

Tube Butt Weld Fittings

Reducing Unions

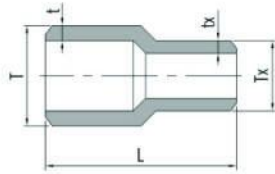

| Metric Tube | | Metric Tube | | | | |
|------------------|-----------------------|------------------|-----------------------|-----------------------|------|----------------------------|
| T-Tube Size (mm) | t-Wall Thickness (mm) | T-Tube Size (mm) | t-Wall Thickness (mm) | Basic Ordering Number | L | Working Pressure psig(bar) |
| 20 | 3.0 | 14 | 2.5 | -WU-MB20-MB14 | 38.1 | 6470(445) |
| 22 | 3.0 | 14 | 2.5 | -WU-MB22-MB14 | 38.1 | 5780(395) |
| 22 | 3.0 | 18 | 2.8 | -WU-MB22-MB18 | 38.1 | 5780(395) |
| 25 | 3.5 | 22 | 3.0 | -WU-MB25-MB22 | 38.1 | 5780(395) |
| 38 | 5.0 | 25 | 3.5 | -WU-MB38-MB25 | 38.1 | 5540(380) |

Tube Butt Weld Fittings

Union Elbows

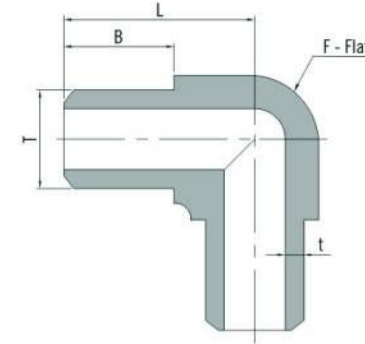

| Fractional Tube | | Basic Ordering Number | Dimension, mm | | | Working Pressure psig(bar) |
|-------------------|------------------------|-----------------------|---------------|------|------|----------------------------|
| T-Tube Size (in.) | t-Wall Thickness (in.) | | L | B | F | |
| 1/4 | 0.065 | -WLU-BW4 | 16.3 | 9.7 | 9.5 | 10320(712) |
| 3/8 | 0.095 | -WLU-BW6 | 18.0 | 9.7 | 11.1 | 9930(685) |
| 1/2 | 0.095 | -WLU-BW8 | 24.4 | 14.2 | 14.3 | 6780(468) |
| 3/4 | 0.120 | -WLU-BW12 | 33.3 | 19.1 | 20.6 | 5530(381) |
| 1 | 0.134 | -WLU-BW16 | 37.1 | 19.1 | 27.0 | 4480(309) |

| Metric Tube | | Basic Ordering Number | Dimension, mm | | | Working Pressure psig(bar) |
|------------------|-----------------------|-----------------------|---------------|------|------|----------------------------|
| T-Tube Size (mm) | t-Wall Thickness (mm) | | L | B | F | |
| 10 | 2.2 | -WLU-MB10 | 18.0 | 9.7 | 11.1 | 8160(563) |
| 14 | 2.5 | -WLU-MB14 | 25.4 | 14.2 | 15.9 | 6280(433) |
| 16 | 2.8 | -WLU-MB16 | 26.2 | 14.2 | 17.5 | 6140(423) |
| 20 | 3.0 | -WLU-MB20 | 33.3 | 19.1 | 20.6 | 5110(352) |
| 22 | 3.0 | -WLU-MB22 | 35.3 | 19.1 | 23.8 | 4620(319) |
| 25 | 3.5 | -WLU-MB25 | 37.1 | 19.1 | 27.0 | 4730(326) |

Union Tees

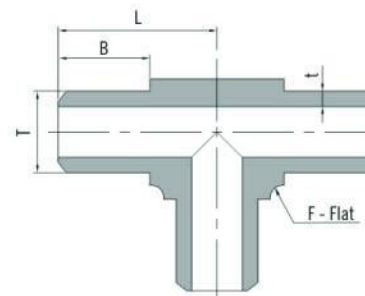

| Fractional Tube | | Basic Ordering Number | Dimension, mm | | | Working Pressure psig(bar) |
|-------------------|------------------------|-----------------------|---------------|------|------|----------------------------|
| T-Tube Size (in.) | t-Wall Thickness (in.) | | L | B | F | |
| 1/4 | 0.065 | -WT-BW4 | 16.3 | 9.7 | 9.5 | 10320(712) |
| 3/8 | 0.095 | -WT-BW6 | 18.0 | 9.7 | 11.1 | 9930(685) |
| 1/2 | 0.095 | -WT-BW8 | 24.4 | 14.2 | 14.3 | 6780(468) |
| 3/4 | 0.120 | -WT-BW12 | 33.3 | 19.1 | 20.6 | 5530(381) |
| 1 | 0.134 | -WT-BW16 | 37.1 | 19.1 | 27.0 | 4480(309) |

| Metric Tube | | Basic Ordering Number | Dimension, mm | | | Working Pressure psig(bar) |
|------------------|-----------------------|-----------------------|---------------|------|------|----------------------------|
| T-Tube Size (mm) | t-Wall Thickness (mm) | | L | B | F | |
| 6 | 1.8 | -WT-MB6 | 16.3 | 9.7 | 9.5 | 12660(873) |
| 8 | 1.8 | -WT-MB8 | 16.3 | 9.7 | 9.5 | 8320(574) |
| 10 | 2.2 | -WT-MB10 | 18.0 | 9.7 | 11.1 | 8160(563) |
| 12 | 2.2 | -WT-MB12 | 24.4 | 14.2 | 14.3 | 6470(446) |
| 14 | 2.5 | -WT-MB14 | 25.4 | 14.2 | 15.9 | 6280(433) |
| 16 | 2.8 | -WT-MB16 | 26.2 | 14.2 | 17.5 | 6140(423) |
| 20 | 3.0 | -WT-MB20 | 33.3 | 19.1 | 20.6 | 5110(352) |
| 22 | 3.0 | -WT-MB22 | 35.3 | 19.1 | 23.8 | 4620(319) |
| 25 | 3.5 | -WT-MB25 | 37.1 | 19.1 | 27.0 | 4730(326) |
| 32 | 4.5 | -WT-MB32 | 49.3 | 23.9 | 34.9 | 4730(326) |

Tube Butt Weld Fittings

Union Crosses

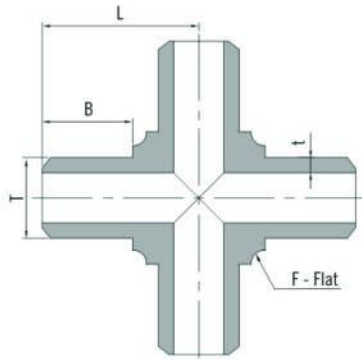

| Fractional Tube | | | Dimension, mm | | | Working Pressure psig(bar) |
|-------------------|------------------------|-----------------------|---------------|------|------|----------------------------|
| T-Tube Size (in.) | t-Wall Thickness (in.) | Basic Ordering Number | L | B | F | |
| 1/4 | 0.065 | -WC-BW4 | 16.3 | 9.7 | 9.5 | 10320(712) |
| 3/8 | 0.095 | -WC-BW6 | 18.0 | 9.7 | 11.1 | 9930(685) |
| 1/2 | 0.095 | -WC-BW8 | 24.4 | 14.2 | 14.3 | 6780(468) |
| 3/4 | 0.120 | -WC-BW12 | 33.3 | 19.1 | 20.6 | 5530(381) |
| 1 | 0.134 | -WC-BW16 | 37.1 | 19.1 | 27.0 | 4480(309) |

| Metric Tube | | | Dimension, mm | | | Working Pressure psig(bar) |
|------------------|-----------------------|-----------------------|---------------|-----|------|----------------------------|
| T-Tube Size (mm) | t-Wall Thickness (mm) | Basic Ordering Number | L | B | F | |
| 6 | 1.8 | -WC-MB6 | 16.3 | 9.7 | 9.5 | 12660(873) |
| 8 | 1.8 | -WC-MB8 | 16.3 | 9.7 | 9.5 | 8320(574) |
| 10 | 2.2 | -WC-MB10 | 18.0 | 9.7 | 11.1 | 8160(563) |

Tube Socket Weld Fittings

Male Connectors

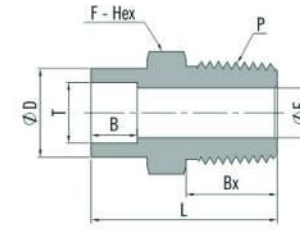

| Fractional Tube | | | Dimension, mm | | | | | | Working Pressure psig(bar) |
|-------------------|------------|-----------------------|---------------|------|------|------|------|------|----------------------------|
| T-Tube Size (in.) | P-NPT Size | Basic Ordering Number | L | D | B | Bx | F | E | |
| 1/4 | 1/4 | -WM-SW4-NT4 | 29.2 | 12.2 | 7.1 | 14.2 | 14.3 | 4.8 | 8400(551) |
| 3/8 | 1/4 | -WM-SW6-NT4 | 31.8 | 15.2 | 7.9 | 14.2 | 15.9 | 7.1 | 8400(551) |
| 3/8 | 3/8 | -WM-SW6-NT6 | 31.8 | 15.2 | 7.9 | 14.2 | 17.5 | 7.1 | 7800(537) |
| 3/8 | 1/2 | -WM-SW6-NT8 | 37.3 | 15.2 | 7.9 | 19.1 | 22.2 | 7.1 | 7700(530) |
| 1/2 | 1/4 | -WM-SW8-NT4 | 33.3 | 18.5 | 9.7 | 14.2 | 19.1 | 7.1 | 6600(454) |
| 1/2 | 3/8 | -WM-SW8-NT6 | 33.3 | 18.5 | 9.7 | 14.2 | 19.1 | 9.6 | 6600(454) |
| 1/2 | 1/2 | -WM-SW8-NT8 | 38.9 | 18.5 | 9.7 | 19.1 | 22.2 | 10.4 | 6600(454) |
| 3/4 | 3/4 | -WM-SW12-NT12 | 45.1 | 26.4 | 11.2 | 19.1 | 27.0 | 15.7 | 5900(406) |
| 1 | 1 | -WM-SW16-NT16 | 53.6 | 34.5 | 15.7 | 23.9 | 34.9 | 22.4 | 5300(365) |

| Metric Tube | | | Dimension, mm | | | | | | Working Pressure psig(bar) |
|------------------|------------|-----------------------|---------------|------|------|------|----|------|----------------------------|
| T-Tube Size (mm) | P-NPT Size | Basic Ordering Number | L | D | B | Bx | F | E | |
| 6 | 1/4 | -WM-SW6-NT4 | 29.2 | 12 | 7.1 | 14.2 | 14 | 4.8 | 8240(566) |
| 12 | 1/2 | -WM-SW12-NT8 | 38.9 | 20.2 | 9.7 | 19.1 | 22 | 5.5 | 6820(470) |
| 14 | 1/4 | -WM-SW14-NT4 | 33.3 | 23.8 | 10 | 14.2 | 24 | 7.1 | 6930(478) |
| 14 | 3/8 | -WM-SW14-NT6 | 35.0 | 23.8 | 10 | 14.2 | 24 | 9.6 | 6930(478) |
| 14 | 1/2 | -WM-SW14-NT8 | 40.0 | 23.8 | 10 | 19.1 | 24 | 10.4 | 6930(478) |
| 16 | 1/4 | -WM-SW16-NT4 | 35.0 | 23.8 | 10.4 | 14.2 | 24 | 7.1 | 6190(426) |
| 16 | 1/2 | -WM-SW16-NT8 | 40.0 | 23.8 | 10.4 | 19.1 | 24 | 11.9 | 6190(426) |
| 18 | 1/4 | -WM-SW18-NT4 | 40.4 | 26.0 | 11.2 | 14.2 | 27 | 7.1 | 6050(417) |
| 28 | 3/4 | -WM-SW28-NT12 | 55.5 | 40 | 20 | 19.1 | 41 | 15.7 | 5040(348) |
| 38 | 1 1/4 | -WM-SW38-NT20 | 68.3 | 50.8 | 22 | 23.9 | 52 | 28.6 | 5230(361) |

Female Connectors

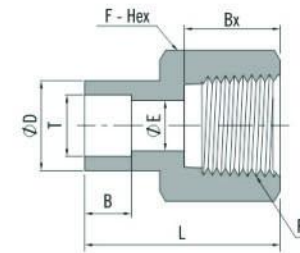

| Fractional Tube | | | Dimension, mm | | | | | | Working Pressure psig(bar) |
|-------------------|------------|-----------------------|---------------|------|------|------|------|------|----------------------------|
| T-Tube Size (in.) | P-NPT Size | Basic Ordering Number | L | D | B | Bx | F | E | |
| 1/8 | 1/8 | -WF-SW2-NT2 | 21.1 | 7.4 | 2.5 | 10.4 | 14.3 | 2.3 | 6500(447) |
| 1/4 | 1/8 | -WF-SW4-NT2 | 26.7 | 12.2 | 7.1 | 10.4 | 14.3 | 4.8 | 6500(447) |
| 1/4 | 1/4 | -WF-SW4-NT4 | 30.0 | 12.2 | 7.1 | 15.0 | 19.1 | 4.8 | 6600(454) |
| 3/8 | 1/4 | -WF-SW6-NT4 | 31.5 | 15.2 | 7.9 | 15.0 | 19.1 | 7.1 | 6600(454) |
| 1/2 | 3/8 | -WF-SW8-NT6 | 34.5 | 18.5 | 9.7 | 15.0 | 22.2 | 10.4 | 5300(365) |
| 1/2 | 1/2 | -WF-SW8-NT8 | 40.4 | 18.5 | 9.7 | 19.8 | 27.0 | 10.4 | 4900(337) |
| 3/4 | 3/4 | -WF-SW12-NT12 | 43.9 | 26.4 | 11.2 | 20.6 | 33.3 | 16.0 | 4600(316) |
| 1 | 1 | -WF-SW16-NT16 | 54.1 | 34.5 | 15.7 | 25.4 | 41.3 | 22.4 | 4400(303) |

| Metric Tube | | | Dimension, mm | | | | | | Working Pressure psig(bar) |
|------------------|------------|-----------------------|---------------|------|------|------|----|------|----------------------------|
| T-Tube Size (mm) | P-NPT Size | Basic Ordering Number | L | D | B | Bx | F | E | |
| 8 | 1/4 | -WF-MS8-NT4 | 27.0 | 14.3 | 7.9 | 15.0 | 19 | 4.8 | 6600(454) |
| 10 | 1/4 | -WF-MS10-NT4 | 29.0 | 16.5 | 7.9 | 15.0 | 19 | 7.1 | 6600(454) |
| 14 | 1/4 | -WF-MS14-NT4 | 32.0 | 23.8 | 10.0 | 15.0 | 24 | 9.5 | 6930(478) |
| 28 | 3/4 | -WF-MS28-NT12 | 54.1 | 40.0 | 20.0 | 20.6 | 41 | 19.8 | 4600(316) |

Tube Socket Weld Fittings

Male Elbows

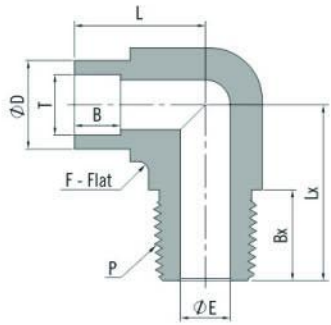

| Fractional Tube | | | NPT Thread | | | | | | | Working Pressure psig(bar) |
|-------------------|------------|-----------------------|---------------|------|------|------|------|------|------|-------------------------------|
| T-Tube Size (in.) | P-NPT Size | Basic Ordering Number | Dimension, mm | | | | | | | |
| | | | L | Lx | D | B | Bx | F | E | |
| 1/4 | 1/4 | -WLM-SW4-NT4 | 20.1 | 26.7 | 14.7 | 7.1 | 14.2 | 12.7 | 4.8 | 8000(551) |
| 3/8 | 1/4 | -WLM-SW6-NT4 | 26.4 | 26.7 | 14.7 | 7.9 | 14.2 | 12.7 | 7.1 | 8000(551) |
| 3/8 | 3/8 | -WLM-SW6-NT6 | 24.6 | 29.7 | 20.2 | 7.9 | 14.2 | 17.5 | 7.1 | 7800(537) |
| 3/8 | 1/2 | -WLM-SW6-NT8 | 25.9 | 36.8 | 23.8 | 7.9 | 19.1 | 20.6 | 7.1 | 7700(530) |
| 1/2 | 1/2 | -WLM-SW8-NT8 | 27.4 | 36.8 | 23.8 | 9.7 | 19.1 | 20.6 | 10.4 | 6600(454) |
| 3/4 | 3/4 | -WLM-SW12-NT12 | 38.9 | 39.6 | 26.4 | 11.2 | 19.1 | 27.0 | 15.7 | 5900(406) |

Tube Socket Weld Fittings

Unions

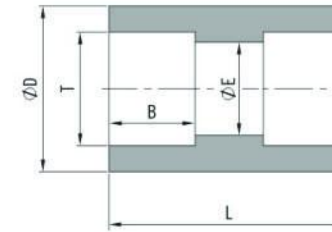

| Fractional Tube | | Dimension, mm | | | | Working Pressure psig(bar) |
|-------------------|-----------------------|---------------|------|------|------|-------------------------------|
| T-Tube Size (in.) | Basic Ordering Number | L | D | B | E | |
| 1/4 | -WU-SW4 | 19.1 | 12.2 | 7.1 | 4.8 | 10700(737) |
| 3/8 | -WU-SW6 | 22.4 | 15.2 | 7.9 | 7.1 | 8100(558) |
| 1/2 | -WU-SW8 | 26.9 | 18.5 | 9.7 | 10.4 | 6600(454) |
| 9/16 | -WU-SW9 | 28.6 | 21.0 | 10.0 | 11.6 | 6260(432) |
| 5/8 | -WU-SW10 | 30.2 | 23.4 | 10.4 | 12.7 | 6200(427) |
| 3/4 | -WU-SW12 | 33.3 | 26.4 | 11.2 | 16.0 | 5900(406) |
| 7/8 | -WU-SW14 | 35.5 | 31.5 | 12.7 | 18.8 | 5730(395) |
| 1 | -WU-SW16 | 36.3 | 36.6 | 15.7 | 22.4 | 5600(385) |

Female Elbows

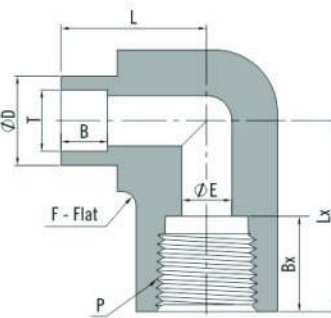

| Fractional Tube | | | NPT Thread | | | | | | | Working Pressure psig(bar) |
|-------------------|------------|-----------------------|---------------|------|------|-----|------|------|------|-------------------------------|
| T-Tube Size (in.) | P-NPT Size | Basic Ordering Number | Dimension, mm | | | | | | | |
| | | | L | Lx | D | B | Bx | F | E | |
| 1/4 | 1/4 | -WLF-SW4-NT4 | 22.9 | 29.7 | 20.2 | 7.1 | 15.0 | 17.5 | 4.8 | 7400(509) |
| 3/8 | 1/4 | -WLF-SW6-NT4 | 25.1 | 29.7 | 20.2 | 7.9 | 15.0 | 17.5 | 7.1 | 7400(509) |
| 3/8 | 1/2 | -WLF-SW6-NT8 | 28.7 | 29.6 | 29.3 | 7.9 | 19.8 | 25.4 | 7.1 | 5700(392) |
| 1/2 | 1/2 | -WLF-SW8-NT8 | 30.2 | 29.6 | 29.3 | 9.7 | 19.8 | 25.4 | 10.4 | 5700(392) |

Reducing Unions

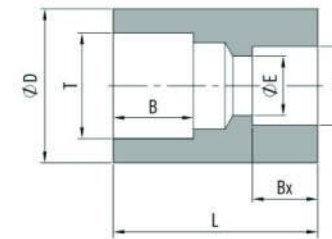

| Fractional Tube | | | Dimension, mm | | | | | Working Pressure psig(bar) |
|-------------------|--------------------|-----------------------|---------------|------|------|------|------|-------------------------------|
| T-Tube Size (in.) | Tx-Tube Size (in.) | Basic Ordering Number | L | D | B | E | Bx | |
| 3/8 | 1/4 | -WU-SW6-SW4 | 22.4 | 15.2 | 7.9 | 4.8 | 7.1 | 8100(558) |
| 1/2 | 1/4 | -WU-SW8-SW4 | 24.3 | 18.5 | 9.7 | 4.8 | 7.1 | 6600(454) |
| 1/2 | 3/8 | -WU-SW8-SW6 | 26.1 | 18.5 | 9.7 | 7.1 | 7.9 | 6600(454) |
| 3/4 | 3/8 | -WU-SW12-SW6 | 29.8 | 26.4 | 11.2 | 7.1 | 7.9 | 5900(406) |
| 3/4 | 1/2 | -WU-SW12-SW8 | 31.6 | 26.4 | 11.2 | 10.4 | 9.7 | 5900(406) |
| 1 | 3/4 | -WU-SW16-SW12 | 32.1 | 34.5 | 15.7 | 16.0 | 11.2 | 5600(385) |

| Metric Tube | | | Dimension, mm | | | | | Working Pressure psig(bar) |
|------------------|-------------------|-----------------------|---------------|------|------|------|------|-------------------------------|
| T-Tube Size (mm) | Tx-Tube Size (mm) | Basic Ordering Number | L | D | B | E | Bx | |
| 14 | 10 | -WU-MS14-MS10 | 26.0 | 23.8 | 10.4 | 7.4 | 7.9 | 6930(478) |
| 25 | 14 | -WU-MS25-MS14 | 30.0 | 34.5 | 15.7 | 10.4 | 10.0 | 5450(376) |
| 25 | 22 | -WU-MS25-MS22 | 35.8 | 34.5 | 15.7 | 19.0 | 13.5 | 5450(376) |

| Metric Tube | | | Dimension, mm | | | | | Working Pressure psig(bar) |
|------------------|--------------------|-----------------------|---------------|------|------|------|------|-------------------------------|
| T-Tube Size (mm) | Tx-Tube Size (in.) | Basic Ordering Number | L | D | B | E | Bx | |
| 20 | 3/4 | -WU-MS20-SW12 | 28.0 | 27.0 | 11.2 | 15.7 | 11.2 | 5510(380) |
| 28 | 3/4 | -WU-MS28-SW12 | 36.8 | 40.0 | 20.0 | 15.7 | 11.2 | 5040(348) |

Tube Socket Weld Fittings

Union Elbows

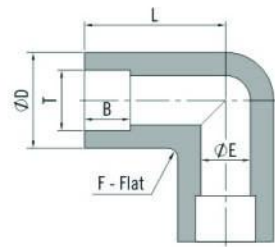

| Fractional Tube | | Dimension, mm | | | | | Working Pressure psig(bar) |
|-------------------|-----------------------|---------------|------|------|------|------|----------------------------|
| T-Tube Size (in.) | Basic Ordering Number | L | D | B | F | E | |
| 1/8 | -WLU-SW2 | 15.0 | 7.4 | 2.5 | 9.5 | 2.3 | 12600(863) |
| 1/4 | -WLU-SW4 | 21.8 | 13.5 | 7.1 | 12.7 | 4.8 | 10700(737) |
| 3/8 | -WLU-SW6 | 26.4 | 16.3 | 7.9 | 14.3 | 7.1 | 8100(558) |
| 1/2 | -WLU-SW8 | 29.7 | 20.6 | 9.7 | 17.5 | 10.4 | 6600(454) |
| 5/8 | -WLU-SW10 | 36.1 | 23.9 | 10.4 | 20.6 | 12.7 | 6200(427) |
| 3/4 | -WLU-SW12 | 39.6 | 26.4 | 11.2 | 25.4 | 16.0 | 5900(406) |
| 1 | -WLU-SW16 | 48.8 | 36.8 | 15.7 | 31.8 | 22.4 | 5600(385) |

| Metric Tube | | Dimension, mm | | | | | Working Pressure psig(bar) |
|------------------|-----------------------|---------------|------|------|------|------|----------------------------|
| T-Tube Size (mm) | Basic Ordering Number | L | D | B | F | E | |
| 10 | -WLU-MS10 | 24.6 | 16.5 | 7.9 | 14.3 | 7.1 | 8100(558) |
| 12 | -WLU-MS12 | 29.7 | 20.2 | 9.7 | 17.5 | 9.5 | 6820(470) |
| 14 | -WLU-MS14 | 29.5 | 23.8 | 9.7 | 20.6 | 10.4 | 6930(478) |
| 16 | -WLU-MS16 | 36.0 | 23.8 | 10.6 | 20.6 | 12.7 | 6190(426) |

Union 45° Elbows

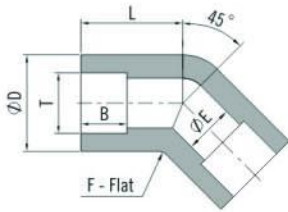

| Fractional Tube | | Dimension, mm | | | | | Working Pressure psig(bar) |
|-------------------|-----------------------|---------------|------|------|------|------|----------------------------|
| T-Tube Size (in.) | Basic Ordering Number | L | D | B | F | E | |
| 1/4 | -WT-SW4 | 15.0 | 13.5 | 7.1 | 12.7 | 4.8 | 10700(737) |
| 3/8 | -WT-SW6 | 19.1 | 16.3 | 7.9 | 14.3 | 7.1 | 8100(558) |
| 1/2 | -WT-SW8 | 21.3 | 20.6 | 9.7 | 17.5 | 10.4 | 6600(454) |
| 3/4 | -WT-SW12 | 28.7 | 26.4 | 11.2 | 25.4 | 16.0 | 5900(406) |
| 1 | -WT-SW16 | 31.8 | 36.8 | 15.7 | 31.8 | 22.4 | 5600(385) |

Union Tees

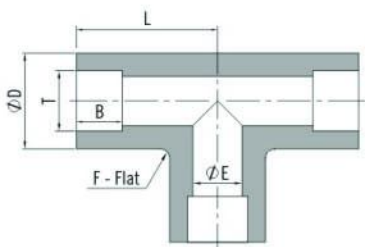

| Fractional Tube | | Dimension, mm | | | | | Working Pressure psig(bar) |
|-------------------|-----------------------|---------------|------|------|------|------|----------------------------|
| T-Tube Size (in.) | Basic Ordering Number | L | D | B | F | E | |
| 1/8 | -WT-SW2 | 15.0 | 7.4 | 2.5 | 9.5 | 2.3 | 12600(863) |
| 1/4 | -WT-SW4 | 21.8 | 13.5 | 7.1 | 12.7 | 4.8 | 10700(737) |
| 3/8 | -WT-SW6 | 26.4 | 16.3 | 7.9 | 14.3 | 7.1 | 8100(558) |
| 1/2 | -WT-SW8 | 29.7 | 20.6 | 9.7 | 17.5 | 10.4 | 6600(454) |
| 5/8 | -WT-SW10 | 36.1 | 23.9 | 10.4 | 20.6 | 12.7 | 6200(428) |
| 3/4 | -WT-SW12 | 39.6 | 26.4 | 11.2 | 25.4 | 16.0 | 5900(406) |
| 1 | -WT-SW16 | 48.8 | 36.8 | 15.7 | 31.8 | 22.4 | 5600(385) |

Tube Socket Weld Fittings

Union Tees

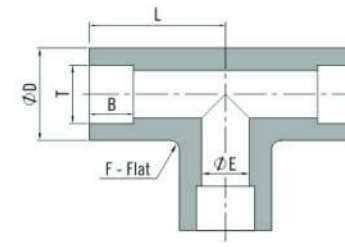

| Metric Tube | | Dimension, mm | | | | | Working Pressure psig(bar) |
|------------------|-----------------------|---------------|------|------|------|------|----------------------------|
| T-Tube Size (mm) | Basic Ordering Number | L | D | B | F | E | |
| 8 | -WT-MS8 | 18.5 | 14.7 | 7.9 | 12.7 | 5.9 | 9790(675) |
| 10 | -WT-MS10 | 24.6 | 16.5 | 7.9 | 14.3 | 7.1 | 8100(558) |
| 12 | -WT-MS12 | 29.7 | 20.2 | 9.7 | 17.5 | 9.5 | 6820(470) |
| 14 | -WT-MS14 | 29.5 | 23.8 | 9.7 | 20.6 | 10.4 | 6930(478) |
| 16 | -WT-MS16 | 36.0 | 23.8 | 10.6 | 20.6 | 12.7 | 6790(426) |
| 20 | -WT-MS20 | 39.6 | 27.3 | 11.2 | 27.0 | 15.9 | 5510(380) |
| 22 | -WT-MS22 | 44.2 | 35.7 | 13.5 | 31.8 | 18.9 | 6850(472) |
| 25 | -WT-MS25 | 48.8 | 36.8 | 15.7 | 31.8 | 22.4 | 5450(376) |

Union Crosses

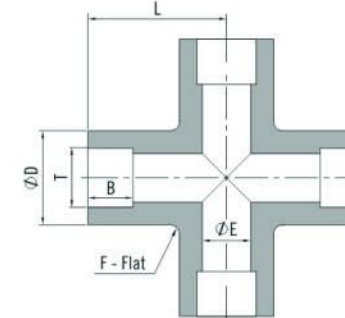

| Fractional Tube | | Dimension, mm | | | | | Working Pressure psig(bar) |
|-------------------|-----------------------|---------------|------|------|------|------|----------------------------|
| T-Tube Size (in.) | Basic Ordering Number | L | D | B | F | E | |
| 1/8 | -WC-SW2 | 15.0 | 7.4 | 2.5 | 9.5 | 2.3 | 12600(863) |
| 1/4 | -WC-SW4 | 21.8 | 13.5 | 7.1 | 12.7 | 4.8 | 10700(737) |
| 3/8 | -WC-SW6 | 26.4 | 16.3 | 7.9 | 14.3 | 7.1 | 8100(558) |
| 1/2 | -WC-SW8 | 29.7 | 20.6 | 9.7 | 17.5 | 10.4 | 6600(454) |
| 5/8 | -WC-SW10 | 36.1 | 23.9 | 10.4 | 20.6 | 12.7 | 6200(428) |
| 3/4 | -WC-SW12 | 39.6 | 26.4 | 11.2 | 25.4 | 16.0 | 5900(406) |
| 1 | -WC-SW16 | 48.8 | 36.8 | 15.7 | 31.8 | 22.4 | 5600(385) |

Pipe Butt Weld Fittings

Male Connectors

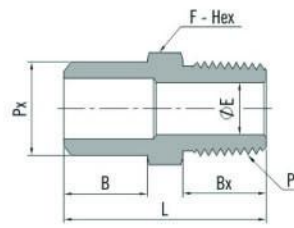

| Pipe | | | NPT Thread | | | | | | Working Pressure psig(bar) |
|----------------------|---------------|-----------------------------|---------------|------|------|------|------|-----------|-------------------------------|
| P-Sch80 Pipe Size | P-NPT Size | Basic Ordering Number | Dimension, mm | | | | | | |
| | | | L | B | Bx | F | E | | |
| 1/4 | 1/4 | -WM-PB4-NT4 | 34.3 | 14.2 | 14.2 | 14.3 | 7.1 | 8120(560) | |
| 1/4 | 1/2 | -WM-PB4-NT8 | 41.3 | 14.2 | 19.1 | 22.2 | 7.7 | 7930(546) | |
| 3/8 | 1/4 | -WM-PB6-NT4 | 34.8 | 14.2 | 14.2 | 17.5 | 7.1 | 6650(459) | |
| 3/8 | 1/2 | -WM-PB6-NT8 | 41.3 | 14.2 | 19.1 | 22.2 | 10.7 | 6650(459) | |
| 1/2 | 1/4 | -WM-PB8-NT4 | 41.3 | 19.1 | 14.2 | 22.2 | 7.1 | 6190(427) | |
| 1/2 | 1/2 | -WM-PB8-NT8 | 46.2 | 19.1 | 19.1 | 22.2 | 11.9 | 6190(427) | |
| 3/4 | 1/4 | -WM-PB12-NT4 | 42.9 | 19.1 | 14.2 | 20.6 | 7.1 | 5040(348) | |
| 3/4 | 1/2 | -WM-PB12-NT8 | 47.8 | 19.1 | 19.1 | 27.0 | 11.9 | 5040(348) | |
| 1 | 1/4 | -WM-PB16-NT4 | 50.0 | 23.9 | 14.2 | 27.0 | 7.1 | 4640(320) | |
| 1 | 1/2 | -WM-PB16-NT8 | 54.9 | 23.9 | 19.1 | 34.9 | 11.9 | 4640(320) | |

Pipe Socket Weld Fittings

Male Connectors

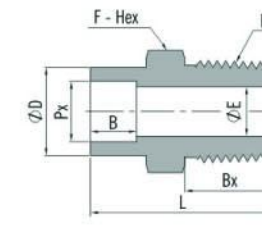

| Pipe | | | NPT Thread | | | | | | Working Pressure psig(bar) |
|-----------------------|---------------|-----------------------------|---------------|------|------|------|------|------|-------------------------------|
| Px-Pipe Size (in.) | P-NPT Size | Basic Ordering Number | Dimension, mm | | | | | | |
| | | | L | D | B | Bx | F | E | |
| 1/4 | 1/4 | -WM-PS4-NT4 | 35.2 | 22.4 | 9.9 | 14.2 | 23.8 | 7.1 | 8100(551) |
| 1/4 | 1/2 | -WM-PS4-NT8 | 40.0 | 22.4 | 9.9 | 19.1 | 23.8 | 9.1 | 7930(546) |
| 3/8 | 3/8 | -WM-PS6-NT6 | 38.0 | 26.2 | 9.9 | 14.2 | 27.0 | 9.7 | 7100(489) |
| 3/8 | 1/2 | -WM-PS6-NT8 | 42.9 | 26.2 | 9.9 | 19.1 | 27.0 | 11.9 | 7100(489) |
| 1/2 | 3/8 | -WM-PS8-NT6 | 40.3 | 31.8 | 9.9 | 14.2 | 33.3 | 9.7 | 6800(468) |
| 1/2 | 1/2 | -WM-PS8-NT8 | 45.2 | 31.8 | 9.9 | 19.1 | 33.3 | 11.9 | 6800(468) |
| 3/4 | 1/2 | -WM-PS12-NT8 | 54.3 | 37.3 | 13.0 | 19.1 | 38.1 | 11.9 | 5800(399) |
| 3/4 | 3/4 | -WM-PS12-NT12 | 54.3 | 37.3 | 13.0 | 19.1 | 38.1 | 15.7 | 5800(399) |
| 1 | 3/4 | -WM-PS16-NT12 | 55.8 | 47.2 | 13.0 | 19.1 | 47.6 | 15.7 | 6100(420) |
| 1 | 1 | -WM-PS16-NT16 | 60.6 | 47.2 | 13.0 | 23.9 | 47.6 | 22.4 | 5460(381) |

Female Connectors

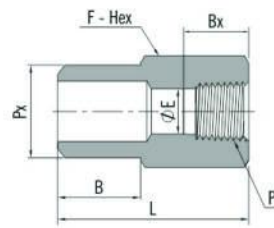

| Pipe | | | NPT Thread | | | | | | Working Pressure psig(bar) |
|----------------------|---------------|-----------------------------|---------------|------|------|------|------|-----------|-------------------------------|
| P-Sch80 Pipe Size | P-NPT Size | Basic Ordering Number | Dimension, mm | | | | | | |
| | | | L | B | Bx | F | E | | |
| 1/4 | 1/2 | -WF-PB4-NT8 | 38.9 | 14.2 | 19.8 | 27.0 | 7.6 | 5040(348) | |
| 3/8 | 1/2 | -WF-PB6-NT8 | 38.9 | 14.2 | 19.8 | 27.0 | 10.7 | 5040(348) | |
| 1/2 | 1/4 | -WF-PB8-NT4 | 37.3 | 19.1 | 15.0 | 22.2 | 10.4 | 6790(463) | |
| 1/2 | 1/2 | -WF-PB8-NT8 | 43.7 | 19.1 | 19.8 | 27.0 | 13.9 | 5040(348) | |

Female Connectors

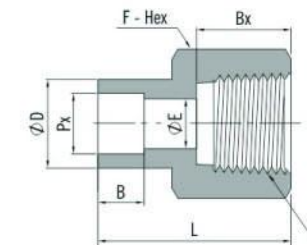

| Pipe | | | NPT Thread | | | | | | Working Pressure psig(bar) |
|-----------------------|---------------|-----------------------------|---------------|------|------|------|------|------|-------------------------------|
| Px-Pipe Size (in.) | P-NPT Size | Basic Ordering Number | Dimension, mm | | | | | | |
| | | | L | D | B | Bx | F | E | |
| 1/4 | 1/4 | -WM-PS4-NT4 | 33.5 | 22.4 | 9.9 | 15.0 | 23.8 | 9.1 | 5460(370) |
| 1/4 | 3/8 | -WM-PS4-NT6 | 33.5 | 22.4 | 9.9 | 15.0 | 23.8 | 9.1 | 6790(463) |
| 3/8 | 3/8 | -WM-PS6-NT6 | 34.1 | 26.2 | 9.9 | 15.0 | 27.0 | 12.4 | 6790(463) |
| 3/8 | 1/2 | -WM-PS6-NT8 | 39.1 | 26.2 | 9.9 | 19.8 | 27.0 | 12.4 | 5040(348) |
| 1/2 | 1/2 | -WM-PS8-NT8 | 40.0 | 31.8 | 9.9 | 19.8 | 33.3 | 15.7 | 6800(468) |
| 1/2 | 3/4 | -WM-PS8-NT12 | 40.6 | 31.8 | 9.9 | 20.6 | 33.3 | 15.7 | 4730(329) |
| 3/4 | 3/4 | -WM-PS12-NT12 | 53.2 | 37.3 | 13.0 | 20.6 | 38.1 | 20.8 | 5800(399) |
| 3/4 | 1 | -WM-PS12-NT16 | 58.1 | 37.3 | 13.0 | 25.4 | 38.1 | 22.4 | 5800(399) |

Unions

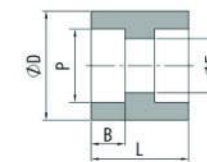

| Pipe | | Dimension, mm | | | | Working Pressure psig(bar) |
|----------------------|-----------------------------|---------------|------|------|------|-------------------------------|
| P-Pipe Size (in.) | Basic Ordering Number | L | D | B | E | |
| 1/8 | -WU-PS2 | 25.7 | 17.1 | 9.9 | 4.0 | 8230(568) |
| 1/4 | -WU-PS4 | 26.9 | 22.4 | 9.9 | 9.1 | 8100(551) |
| 3/8 | -WU-PS6 | 28.4 | 26.2 | 9.9 | 12.4 | 7100(489) |
| 1/2 | -WU-PS8 | 28.4 | 31.8 | 9.9 | 15.7 | 6800(468) |
| 3/4 | -WU-PS12 | 44.5 | 37.3 | 13.0 | 20.8 | 5800(399) |
| 1 | -WU-PS16 | 44.5 | 47.2 | 13.0 | 26.7 | 6100(420) |

Weld Adapters

Tube Butt Weld to Tube Socket Weld

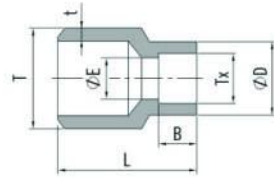

| Fractional Tube | | | | Dimension, mm | | | | Working Pressure psig(bar) |
|-------------------|------------------------|--------------------|-----------------------|---------------|------|------|------|-------------------------------|
| T-Tube Size (in.) | t-Wall Thickness (in.) | Tx-Tube Size (in.) | Basic Ordering Number | L | B | D | E | |
| 1/4 | 0.083 | 1/8 | -WA-BW4-SW2 | 14.2 | 2.5 | 8.0 | 2.3 | 12600(868) |
| 3/8 | 0.095 | 1/4 | -WA-BW6-SW4 | 19.1 | 7.1 | 12.2 | 4.8 | 8200(564) |
| 1/2 | 0.095 | 1/4 | -WA-BW8-SW4 | 22.4 | 7.1 | 12.7 | 4.8 | 7500(516) |
| 1/2 | 0.095 | 3/8 | -WA-BW8-SW6 | 22.4 | 7.9 | 15.2 | 7.1 | 7500(516) |
| 3/4 | 0.120 | 1/2 | -WA-BW12-SW8 | 28.4 | 9.7 | 18.5 | 10.4 | 6300(434) |
| 1 | 0.134 | 1/2 | -WA-BW16-SW8 | 35.1 | 9.7 | 18.5 | 10.4 | 5300(365) |
| 1 | 0.134 | 3/4 | -WA-BW16-SW12 | 38.1 | 11.2 | 26.4 | 16.0 | 5300(365) |

Pipe Butt Weld to Tube Socket Weld

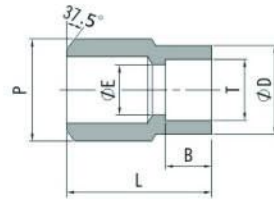

| Pipe | | | Fractional Tube | | | | Working Pressure psig (bar) |
|-------------------|-------------------|-----------------------|-----------------|------|------|------|--------------------------------|
| P-Sch80 Pipe Size | T-Tube Size (in.) | Basic Ordering Number | Dimension, mm | | | | |
| | | | L | B | D | E | |
| 1/4 | 1/4 | -WA-PB4-SW4 | 22.4 | 7.1 | 12.2 | 4.8 | 10810 (744) |
| 3/8 | 1/4 | -WA-PB6-SW4 | 26.2 | 7.9 | 12.2 | 4.8 | 8500 (586) |
| 3/8 | 3/8 | -WA-PB6-SW6 | 26.2 | 7.9 | 15.2 | 7.1 | 8500 (586) |
| 3/8 | 1/2 | -WA-PB6-SW8 | 25.4 | 9.7 | 18.5 | 10.4 | 6930 (476) |
| 1/2 | 1/4 | -WA-PB8-SW4 | 28.4 | 7.1 | 12.2 | 4.8 | 8190 (563) |
| 1/2 | 3/8 | -WA-PB8-SW6 | 28.4 | 7.9 | 15.2 | 7.1 | 8190 (563) |
| 1/2 | 1/2 | -WA-PB8-SW8 | 30.2 | 9.7 | 18.5 | 10.4 | 6930 (476) |
| 3/4 | 1/4 | -WA-PB12-SW4 | 38.1 | 7.1 | 12.2 | 4.8 | 6930 (476) |
| 3/4 | 3/8 | -WA-PB12-SW6 | 38.1 | 7.9 | 15.2 | 7.1 | 6930 (476) |
| 3/4 | 1/2 | -WA-PB12-SW8 | 38.1 | 9.7 | 18.5 | 10.4 | 6930 (476) |
| 3/4 | 3/4 | -WA-PB12-SW12 | 38.1 | 11.2 | 26.4 | 16.0 | 6190 (483) |
| 1 | 3/8 | -WA-PB16-SW6 | 35.1 | 7.9 | 15.2 | 7.1 | 6300 (434) |
| 1 | 1/2 | -WA-PB16-SW8 | 39.6 | 9.7 | 18.5 | 10.4 | 6300 (434) |